PHYSICAL SCIENCE

8780/04

Paper 4 Advanced Practical Skills

October/November 2017

CONFIDENTIAL INSTRUCTIONS

Great care should be taken to ensure that any confidential information given does not reach the candidates either directly or indirectly.

No access to the Question Paper is permitted in advance of the examination.



The Supervisor's attention is drawn to the form on pages 11 and 12 which must be completed and returned with the scripts.

If you have any queries regarding these Confidential Instructions, please contact Cambridge stating the Centre number, the nature of the query and the syllabus number quoted above.

email info@cie.org.uk
phone +44 1223 553554
fax +44 1223 553558

This document consists of **10** printed pages and **2** blank pages.

Safety

Supervisors are advised to remind candidates that **all** substances in the examination should be treated with caution. Only those tests described in the Question Paper should be attempted. Pipette fillers and safety goggles should be used where necessary.

In accordance with COSHH (Control of Substances Hazardous to Health) Regulations, operative in the UK, a hazard appraisal of the examination has been carried out.

The following hazard codes are used where relevant.

C	corrosive	MH	moderate hazard
HH	health hazard	T	acutely toxic
F	flammable	O	oxidising
N	hazardous to the aquatic environment		

The attention of Centres is drawn to any local regulations relating to safety, first aid and disposal of chemicals.

'Hazard Data Sheets', relating to materials used in this examination, should be available from your chemical supplier.

Before the examination

- 1 These Confidential Instructions detail the apparatus required for the experiments in the Question Paper. **Access to the Question Paper is NOT permitted in advance of the examination.** The contents of these Confidential Instructions must not be revealed either directly or indirectly to the candidates.
- 2 **Preparation of materials**
Where quantities are specified for each candidate, they are sufficient for the experiments described in the Question Paper to be completed.
In preparing materials, the bulk quantity for each substance should be increased by 25% as spare material should be available to cover accidental loss. More material may be supplied if requested by candidates, without penalty.
All solutions should be bulked and mixed thoroughly before use to ensure uniformity.
Every effort should be made to keep the concentrations accurate to within one part in two hundred of those specified.
If the concentrations differ slightly from those specified, the Examiners will make the necessary allowance. They should be informed in the Supervisor's Report of the exact concentrations.
- 3 **Labelling of materials**
Materials must be labelled as specified in these Confidential Instructions. It may be required for some materials to be labelled but **without** the identities being included on the label.
It should be noted that descriptions of materials given in the Question Paper may not correspond with the specifications in these Confidential Instructions. **The candidates must assume the descriptions given in the Question Paper.**
- 4 **Size of group**
In view of the difficulty in preparing large quantities of solution of uniform concentration, it is recommended that the maximum number of candidates per group be 30 and that separate supplies of solutions be prepared for each group.
- 5 **Number of sets of apparatus**
The minimum number of sets of apparatus provided for each experiment is half the number of candidates taking the examination. There should, in addition, be a few spare sets of apparatus available in case problems arise during the examination.

The examination

1 Organisation of the examination

Essential Information relating to the conduct and invigilation of the practical examination is given in the Handbook for Centres.

Candidates should be allowed access to the apparatus for each experiment for 45 minutes only. After spending 45 minutes on one experiment, candidates should change over to the other experiment. The order in which a candidate attempts the two experiments is immaterial.

2 Assistance to candidates

Supervisors should make the following announcement at the start of the examination:

'The Examiners do not want you to waste time when you are unable to do any experiment. Any candidate who is unable to get results with an experiment may ask for help. The extent of this help will be reported to the Examiners, who may make a deduction of marks.'

Assistance should only be given when it is asked for by a candidate, or as directed in the Notes sections of these Confidential Instructions, or where apparatus is seen to have developed a fault. Assistance should be restricted to enabling candidates to make observations and measurements. Observations and measurements must not be made for candidates, and no help should be given with data analysis or evaluation.

All assistance given to candidates must be reported on the Supervisor's Report.

3 Colour blindness

It is permissible to advise candidates who request assistance on colours of, for example, precipitates and solutions (especially titration end-points). Please include with the scripts a note of the candidate numbers of such candidates. Reporting such cases with the scripts removes the need for a Special Consideration Form.

Candidates who are red/green colour-blind do not generally have significant difficulty.

4 Faulty apparatus

In cases of faulty apparatus that prevents the required measurements from being taken, the Supervisor may allow extra time to give the candidate a fair opportunity to perform the experiment as if the fault had not been present.

5 Supervisor's Results

If asked to do so in the Confidential Instructions, the Supervisor, or other competent physical scientist, should carry out the required experimental work **out of sight of the candidates**. Access to the Question Paper is NOT permitted in advance of the examination.

Supervisor's Results are required for each session and each laboratory used in that session, and each set of solutions supplied. The Question Paper front cover requests candidates to fill in details of the examination session and the laboratory used for the examination. It is essential that each packet of scripts contains a copy of the Supervisor's Results as the candidate's work cannot be assessed accurately without such information.

After the examination

Each envelope returned to Cambridge must contain the following items:

- 1 the scripts of those candidates specified on the barcode label provided,
- 2 a copy of the Supervisor's Results if required by the Confidential Instructions,
- 3 the Supervisor's Report, including details of any difficulties experienced by candidates (see pages 11 and 12),
- 4 the Attendance Register,
- 5 a plan of work benches, giving details by candidate number of the places occupied by the candidates for each experiment and session.

Instructions for Preparing Apparatus and Materials

In addition to the fittings ordinarily contained in a science laboratory, the apparatus and materials specified below will be necessary.

Question 1

Apparatus requirements (per set of apparatus, unless otherwise specified)

- 1 × power supply of electromotive force (e.m.f.) 6V, labelled **P**, made up of 4 cells in series (AA or C), in a suitable holder. See note 1.
- 1 × power supply of e.m.f. 4.5V, labelled **Q**, made up of 3 cells in series (AA or C), in a suitable holder. See note 1.
- 2 × switches labelled **S₁** and **S₂**.
- 1 × 1.20m length of 30 swg nichrome wire taped to a metre rule. The taping needs to be near each end of the wire. The ruler must be calibrated in mm. See note 2.
- 1 × 82Ω resistor labelled **N**; the value of this resistor should be obscured. See note 3.
- 6 × 47Ω resistors. See note 3.
- 1 × digital voltmeter (this should be suitable to measure to 0.01 V and be direction sensitive, i.e. the voltmeter should distinguish between positive and negative directions).
- 9 × connecting leads.
- 1 × jockey or other knife edge connector. This may be a small screwdriver connected to a lead using a crocodile clip.
- 1 × crocodile clip (more may be needed depending on the type of connectors used).

Notes

- 1 The precise size or e.m.f. of the cells is not important, but all **seven** cells must be identical.
- 2 If the metre rule has scales running in both directions (0–100 and 100–0), the 100–0 scale should be obscured with opaque tape.
- 3 The resistors should be soldered in series with the unknown resistor at the beginning of the chain. The conducting section labelled **X** in Fig. 1.1 between the 82Ω resistor (**N**) and the first 47Ω resistor should be taped over so that an electrical connection cannot be made. The label **X** is not required for the candidates.

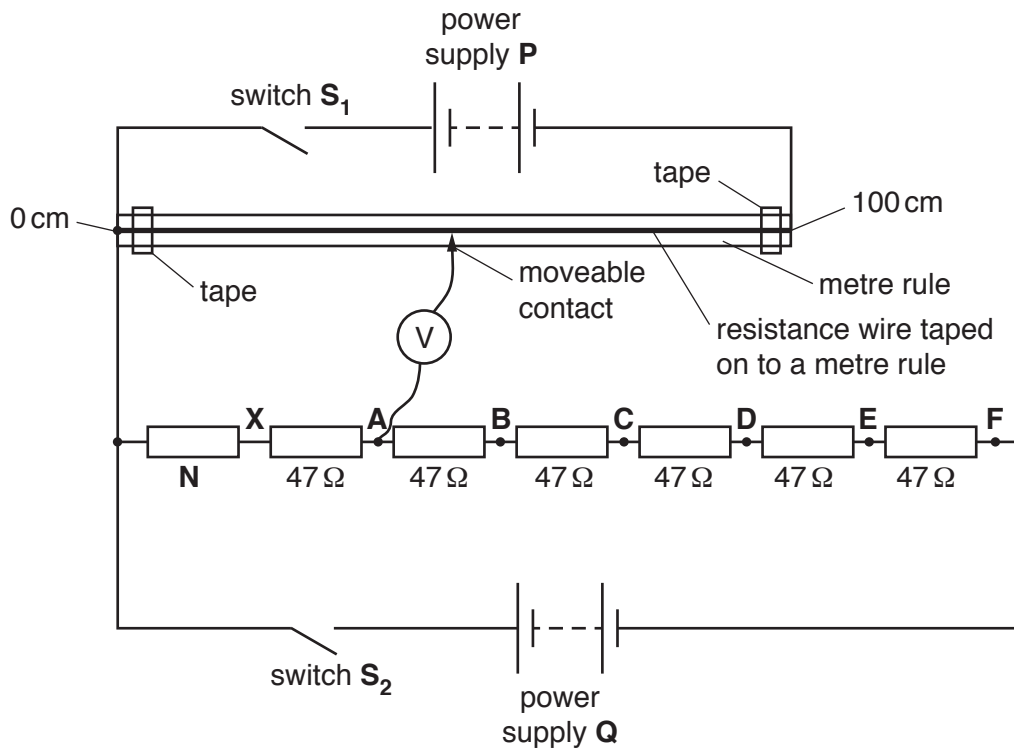

Fig. 1.1

Action at changeover

The circuit should be as shown in Fig. 1.1. The e.m.f. of both power supplies should be checked. Spare cells should be available.

Information required

e.m.f. of power supply **P**

e.m.f. of power supply **Q**

Question 2

Under no circumstances must the identity of solution P or the concentration of solution Z be divulged to candidates.

Apparatus required for each candidate

- 4 × clean test-tubes
- 1 × test-tube rack
- 4 × 50cm³ measuring cylinders
- 2 × polystyrene cups (approximately 150cm³)
- 2 × 250cm³ beakers capable of holding the polystyrene cup to prevent it from falling over
- 1 × thermometer with a range of –5 °C to 50 °C and 0.2 °C divisions
- 6 teat pipettes
- paper towels
- access to distilled (deionised) water
- Solutions **X**, **Y**, **Z** and **P**. See Note 3 and table on page 8.

Chemicals

See table

Notes

- 1 Spare materials and equipment should be available and can be provided without penalty.
Candidates should be made aware of this.
- 2 Suitable eye protection and disposable plastic gloves should be used where necessary.
- 3 Solutions **X**, **Y** and **Z** must be prepared at least 24 hours before the examination and kept in the examination room to ensure that they are all at the temperature of the room.

Chemicals required for Question 2

Particular requirements

hazard	label	per candidate	identity	notes (Hazard symbols given in this column are for the raw materials.)
[C]	X	70 cm ³ in a suitable container	1.00 mol dm ⁻³ sulfuric acid	Cautiously pour 55 cm ³ of concentrated (98%) sulfuric acid [C] into 500 cm ³ of distilled water with continuous stirring. Make the solution up to 1 dm ³ with distilled water. Care – concentrated H ₂ SO ₄ is very corrosive. The concentrated acid must be added to the water and not the other way round.
[C]	Y	150 cm ³ in a suitable container	2.00 mol dm ⁻³ sodium hydroxide	Dissolve 80.0 g of NaOH [C] in each dm ³ of solution. Care – the process of solution is exothermic and any concentrated solution is very corrosive.
[MH]	P	25 cm ³	A mixture of magnesium sulfate and iron(III) sulfate both about 0.1 mol dm ⁻³	This solution must be made with distilled or deionised water. The concentrations in this solution are not critical and can be made with approximately 0.1 mol dm ⁻³ of each sulfate in the mixture (about 1.2 g magnesium sulfate and 4.0 g iron(III) sulfate in every 100 cm ³ of solution).
[C]	Z	70 cm ³	Approximately 0.5 g of magnesium ribbon dissolved in each 100 cm ³ of 1.00 mol dm ⁻³ sulfuric acid	This solution must be made up with 1.00 mol dm ⁻³ sulfuric acid as accurately as possible. Typically, a 25 cm length of magnesium ribbon has a mass of 0.48 g. Candidates should not be told the concentration of this solution.

The standard bench reagents are set out below. If necessary, they may be made available from a communal supply; however, the attention of the Supervisors should be drawn to the fact that such an arrangement may enhance the opportunity for malpractice between candidates.

hazard	label	per candidate	identity	notes (Details for making solutions can be found in the syllabus appendix.)
[HH][O]	barium nitrate [or aqueous barium chloride]	5 cm ³	0.1 mol dm ⁻³ barium nitrate or 0.1 mol dm ⁻³ barium chloride	Dissolve 26.1 g of Ba(NO ₃) ₂ [HH][O] (or 24.4 g of BaCl ₂ ·2H ₂ O [T]) in each dm ³ of solution.
[MH][N]	aqueous silver nitrate	5 cm ³	0.05 mol dm ⁻³ silver nitrate	Dissolve 8.5 g of AgNO ₃ [C][N][O] in each dm ³ of solution.
[MH]	dilute hydrochloric acid	10 cm ³	2.0 mol dm ⁻³ hydrochloric acid	Dilute 170 cm ³ of concentrated (35–37%; approximately 11 mol dm ⁻³) acid [C][MH] to 1 dm ³ . Care – the concentrated acid must be added to the water and not the other way round.
[C]	sodium hydroxide solution	20 cm ³	1.0 mol dm ⁻³ sodium hydroxide	Dissolve 40.0 g of NaOH [C] in each dm ³ of solution. Care – the process of solution is exothermic and any concentrated solution is very corrosive.
[C][O]	dilute nitric acid	10 cm ³	1.0 mol dm ⁻³ nitric acid	Dilute 64 cm ³ of concentrated (70% w/v) acid [C] to 1 dm ³ .
[C][MH][N]	dilute ammonia solution	20 cm ³	1.0 mol dm ⁻³ ammonia solution	Dilute 56 cm ³ of concentrated (35%) ammonia [MH][N] to 1 dm ³ .

BLANK PAGE

Permission to reproduce items where third-party owned material protected by copyright is included has been sought and cleared where possible. Every reasonable effort has been made by the publisher (UCLES) to trace copyright holders, but if any items requiring clearance have unwittingly been included, the publisher will be pleased to make amends at the earliest possible opportunity.

To avoid the issue of disclosure of answer-related information to candidates, all copyright acknowledgements are reproduced online in the Cambridge International Examinations Copyright Acknowledgements Booklet. This is produced for each series of examinations and is freely available to download at www.cie.org.uk after the live examination series.

Cambridge International Examinations is part of the Cambridge Assessment Group. Cambridge Assessment is the brand name of University of Cambridge Local Examinations Syndicate (UCLES), which is itself a department of the University of Cambridge.

This form should be completed and sent to the Examiner with the scripts.

SUPERVISOR'S REPORT FORM

The Supervisor's Report should give full details of:

- (a)** any help given to a candidate (including the nature of the help given and the name and candidate number of the candidate),
- (b)** any cases of faulty apparatus (including the nature of the problem, the action taken to rectify it, any additional time allowed, and the name and candidate number of the candidate),
- (c)** assistance provided in the case of colour blindness,
- (d)** any other difficulties experienced by candidates, or any other information that is likely to assist the Examiner, especially if this information cannot be discovered in the scripts.

Cases of individual hardship, such as illness, bereavement or disability, should be reported directly to Cambridge on the normal Special Consideration form.

Supervisor's Report

Information required by Examiners

1. A sample set of numerical results, clearly marked 'Supervisor's Results'. These may be recorded on a spare copy of the Question Paper.
2. A plan of work benches for each session/laboratory.

Declaration (to be signed by the Supervisor)

The preparation of this practical examination has been carried out so as to maintain fully the security of the examination.

Signed

Name (in block capitals)

Centre number

Centre name

If scripts are required by Cambridge to be despatched in more than one envelope, it is essential that a copy of the relevant Supervisor's Report, Supervisor's Results and the appropriate seating plan(s) are sent inside **each** envelope.